

Escape Sign Panel Luminaire

SpiritLED 28



- Exclusive escape sign panel luminaire in LED technology
- Frameless design with pictogram integrated in acrylic glass
- Very good perceptibility via high luminance of white contrast colour > 500 cd/m² according to DIN 4844-1, and high uniformity $L_{min}/L_{max} > 0.5$
- Special LED converter, with integrated monitoring module for single luminaire monitoring
- Increased safety with use of 3-chip LEDs
- Minimum service requirement due to high service life of the LEDs (50,000 hours)
- Shortened inspection effort due to CEWA GUARD technology
- Automatic function monitoring of up to 20 luminaires per circuit
- Reduced installation expenditures by STAR technology
- Freely programmable mixed operation of the switching modes per luminaire in one circuit



SpiritLED 28
wire suspension
with panel PU/PU



SpiritLED 28 Wall mounting
with panel PL/PR-R

Viewing distance	28 m
Luminous flux Φ_E/Φ_N at the end of rated operating time	100 %
Housing material	Plastic
Weight	2.0 kg
Housing colour	Silver
Type of mounting	Recessed and surface ceiling mounting
Connection terminals	Clamp terminal 2.5 mm ² reverse-polarity protected
Connection voltage	220 – 240 V AC, 50/60 Hz 176 – 275 V DC
Current consumption with battery operation	16 mA
Power consumption mains operation (apparent power/effective power)	6.6 VA / 3.7 W
Permissible ambient temperature	-10 °C to +40 °C
Light source	LED batten with 3-chip LEDs

Ordering details

Type		Order No.
SpiritLED 28 PL/PR – LED panel with pictogram PL/PR and LED-module (mounting kit is required) acc. to DIN 4844		400 71 352 010
SpiritLED 28 PU/PU – LED panel with pictogram PU/PU and LED-module (mounting kit is required) acc. to DIN 4844		400 71 352 011
SpiritLED 28 PU/Blind – LED panel with pictogram PU/Blind and LED-module (mounting kit is required) acc. to DIN 4844		400 71 352 012
SpiritLED 28 PL/PR-R* 90° – LED panel with pictogram PL/PR and LED-module (mounting kit is required) acc. to DIN 4844		400 71 352 244
SpiritLED 28 PL/PR-W* 90° – LED panel with pictogram PL/PR and LED-module (mounting kit is required) acc. to DIN 4844		400 71 352 245
SpiritLED 28 PL/PR – LED panel with pictogram PL/PR and LED-module (mounting kit is required)		400 71 349 455
SpiritLED 28 PU/PU – LED panel with pictogram PU/PU and LED-module (mounting kit is required)		400 71 349 534
SpiritLED 28 PU/Blind – LED panel with pictogram PU/Blind and LED-module (mounting kit is required)		400 71 349 590
SpiritLED 28 PL/PR-R* 90° – LED panel with pictogram PL/PR and LED-module (mounting kit is required)		400 71 352 246
SpiritLED 28 PL/PR-W* 90° – LED panel with pictogram PL/PR and LED-module (mounting kit is required)		400 71 352 247

* R = Arrow from mounting wall

W = Arrow to mounting wall

** Degree of protection recessed ceiling mounting kit IP 20

Escape Sign Panel Luminaire SpiritLED 28

Accessories

Type	Order No.
Recessed ceiling mounting kit with wire suspension, incl. LED supply	400 71 352 007
Surface mounting kit, incl. LED supply, colour aluminium	400 71 352 005
Surface mounting kit with wire suspension, incl. LED supply, colour aluminium	400 71 352 006

Dimensions in mm

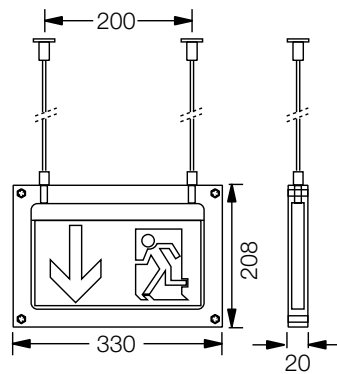

Recessed ceiling mounting
with wire suspension

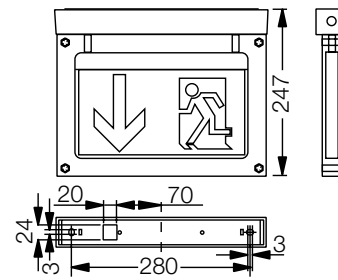

Recessed ceiling mounting

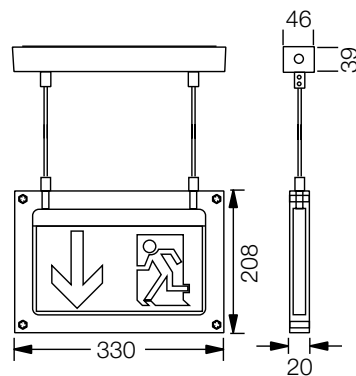

Surface ceiling mounting
with Seilabhängung

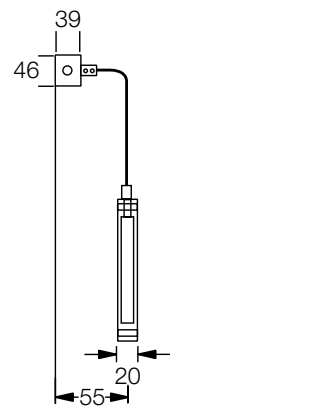

Wall parallel with wire suspension